

Operator's Safety and Service Walk Behind Street Concrete Saw

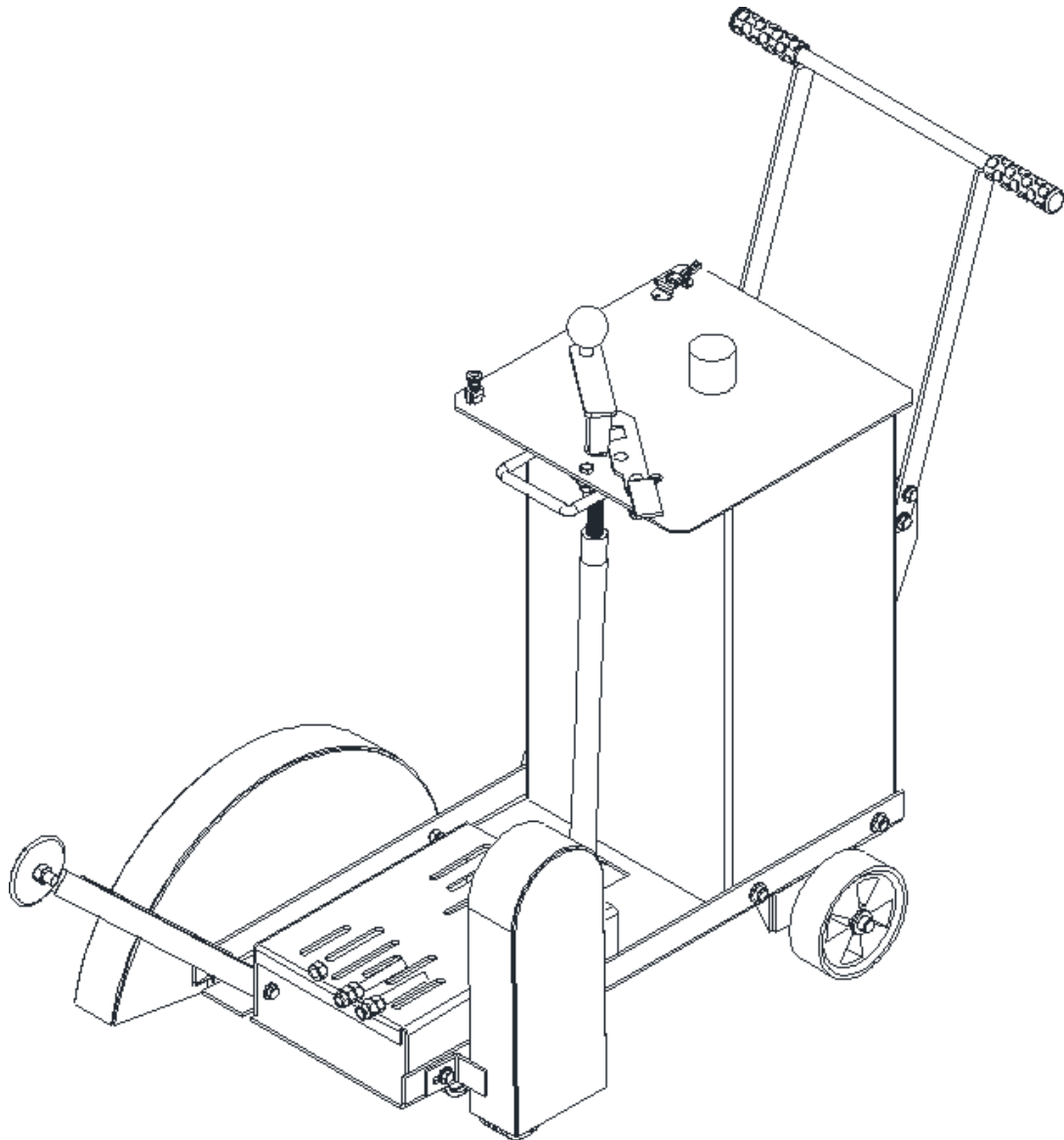

MSM/MCS-1

JCS/JCST (SELF-PROP)



01012019

It is the OWNER'S RESPONSABILITY to communicate information on the
SAFE USE and OPERATION of this machine to the operators.

TABLE OF CONTENTS

1.Serial Number Location.....	3
2.Parts Ordering Procedure	3
3.Operating Instructions	4
4.Safety Precaution	6
5.Safety Notice & Decals	8
6.Before Operating.....	9
7.Operation Instruction.....	9
8.Adding Fluids & Towing.....	10
9.Service Instructions	12
10.Maintenance Schedule	13
11.Replacements.....	14
12.Equipment General Specs	16
13.equipment specs	17
14. Torque chart.....	17
15.Warehouse Locations.....	19
16.Additional Notes	20
17.Parts List Breakdown.....	Attachment

1. SERIAL NUMBER LOCATION

The model/serial number decal is located on the shroud assembly (cowl).



(Write model number)



(Write serial number)

The unit year of manufacturing can be determined by its serial number. So, keep this information handy at all times, use your unit serial number when ordering parts.

This Unit warranty is stated in this Operational and Safety manual on page 16. Failure to return warranty registration card renders the warranty null and void.

An engine owner’s manual is also attached to every unit. Engine parts must be order from any authorized HONDA dealer, or other if different than HONDA. Refer to the engine owner’s manual lo learn about specifications and part identification.

2. PARTS ORDERING PROCEDURE:

Parts must be ordered through your local distributor or online using our partner internet parts dealers online. If you can’t locate a local distributor in your area visit us online at www.tkequip.com for information so we can locate the nearest dealer and contact numbers for assistance.

Order Parts All Dealers are welcome to send us an email to: sevice@btmequipment.com or parts@btmequipment.com



All Dealers are welcome to order parts via fax by dialing **(956) 462-2500**



All Dealers are welcome to order parts by dialing our Number **(956) 796-9411**

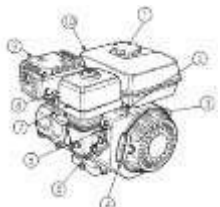

All HONDA warranties and parts ordering must be through your Honda dealers. Please visit <https://engines.honda.com/dealer-locator> for more information.

REMEMBER – You own the best. If repairs are needed use only OEM purchased parts from authorized distributors.

ALWAYS HAVE READY:

1. Dealer Account number
2. Dealer Name and Address
3. Shipping address and method of shipping if different than billing address.
4. Applicable model and serial number of machine(s).
5. Item part number(s), description, and quantity.

3. OPERATING INSTRUCTIONS

This Operation manual contains only standard parts. Variations of these parts as well as other special accessories are not included. Contact your local distributor for assistance in identifying parts not included in this manual.

ASSEMBLY INSTRUCTIONS

1. Remove the saw and all components from its shipping crate. You will see:
 - Preassembled Saw with no Blade, unless diamond blade was purchased separately and asked to be installed before shipping.
 - Handles will be attached but packed down for better shipping.

Note: All installation hardware must be inserted into its respective location on the unit, reference parts breakdown for more details if needed.

2. If saw is shipped double stack, using appropriated equipment, hold the upper saw from the frame, unbolt the upper saw from the supports, and bring the saw to the ground and then proceed to bring the lower saw to the ground, using the same appropriated equipment.



Warning: failure to use proper lifting equipment could cause saw to fall and cause serious injury.

3. If saw is shipped regular, using appropriated equipment, bring the saw to the ground from its shipping pallet.
4. Unbolt the handle control assembly, flip it over into the walk behind style, and proceed to bolt again and torque to 60 ft.-lbs.
5. Bring the saw up using the crank lift and lock at the desired position and lock handle.

ARBOR OR ENGINE SHEAVE INSTALLATION/REMOVAL

1. Standard sheaves on this saw are of the QD design. To remove sheave, remove belt guard and remove belts.
2. 3 remove (3) hex head cap screw from (position A) sheave bushing.
3. Install (3) caps screw in tapped holes in (position B) sheave bushing.
4. Tighten tree caps screw alternately and equally until sheaves loosens from bushing.
5. Loosen set screw over keyway in bushing and remove sheave/bushing.
6. Wipe all parts clean before assembly. A light coat of grease can be applied to engine shaft or arbor shaft. Do not place lubricants on tapered bore of sheaves, tapered hub of Q.D. bushing or bolt threads.
7. To install sheaves, line up drilled holes in bushing with tapped holes in sheaves and install cap screw.
8. Align bushing on arbor shaft with bushing on engine shaft and tighten set screw over keyway.
9. Tighten (3) cap screw alternately and equally to 10 ft. lbs. of torque and inspect alignment.
10. Verify sheave alignment with a straight edge to reaches between the two sheaves. The sheaves should be aligned with each other to within 1/32".
11. Readjust sheave on arbor shaft as required to achieve alignment of writhing 1/32".
12. When sheaves are aligned properly, install and pretension belts.

BLADE INSTALLATION/REMOVAL



IF BLADE GUARD IS TO BE REMOVED TO SERICE BLADE, ITMUST B REPLACED BEFORE RUNNING SAW. NEVER RUN SAW WITHOUT BLADE GUARDINSTALLED

1. Turn lift/lower crank to raise saw. Lock crank in place with locking handle.
2. Disconnect Spark plug wire.
3. Remove arbor bolt, lock washer, and outside blade collar with pin.
4. Clean and inspect arbor, lade, collars and bolts
5. Verify inside blade collar is fully engaged on arbor and key is positioned properly.
NOTE: MSC-1 uses 4" diameters collars.
6. Mount blade over shoulder of outside collar. Pin must engage 3/8" diameter hole in blade. Many diamonds blades will have directional arrow on blade.
7. Re-Install outside blade collar and blade onto arbor shaft with 1" diameter shoulder and 3/8" pin engaging inside collar. Install bolt and torque at 60 ft. lbs.

8. Be sure that blade is installed to rotate in correct direction and that the saw is set up for required RPM.
6. Wet cutting diamonds blades must be used with water. Turn water on BEFORE STARTING CUTTING.



4. SAFETY PRECAUTIONS



WARNING



CALIFORNIA – Proposition 65 Warning

Engine exhaust and some of its constituents and some dust created by power sanding, sawing, grinding, drilling and other construction activities contains chemicals known to the State of California to cause cancer, birth defects and other reproductive harm.

Some examples of these chemicals are:

- Lead from lead-based paints
- Crystalline silica from bricks
- Cement and other masonry products
- Arsenic and chromium from chemically treated lumber

Your risk from these exposures varies, depending on how often you do this type of work. To reduce your exposure to these chemicals:

ALWAYS work in a well ventilated area, and work with approved safety equipment, such as dust masks that are specially designed to filter out microscopic particles.

READ AND STUDY THE FOLLOWING SAFETY INFORMATION BEFORE ATTEMPTING TO OPERATE THIS EQUIPMENT. IN ADDITION, ENSURE THAT EVERY INDIVIDUAL WHO OPERATES OR WORKS WITH THIS EQUIPMENT IS FAMILIAR WITH THESE SAFETY PRECAUTIONS.

IT IS THE OPERATOR'S RESPONSIBILITY TO OPERATE OUR MACHINES ONLY WHEN WEARING THE PROPER PROTECTION RECOMMENDED BY THE OCCUPATIONAL SAFETY AND HEALTH ADMINISTRATION. HARM OR DEATH BY INHALING PARTICLES OR OTHER PHYSICAL INJURY MAY OCCUR IF THIS MACHINE IS OPERATED WITHOUT USING THE PROPER SAFETY GEAR, OR FOLLOWING THE APPROPRIATE PROCEDURES IN THIS MANUAL.

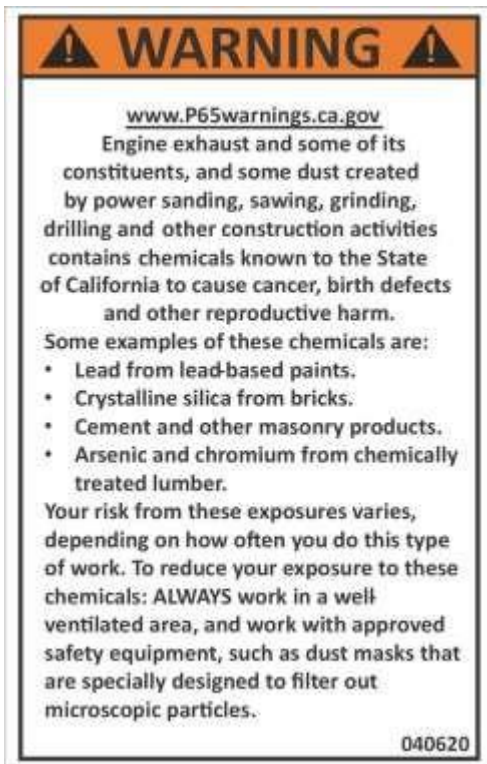

WARNING - LETHAL EXHAUST GAS!

An internal combustion engine discharges carbon monoxide, which is a poisonous and odorless invisible gas. Death or serious illness may result if inhaled. Operate only in an area with good ventilation.

NEVER IN A CONFINED AREA!

WARNING - DANGEROUS FUELS!

Use extreme caution when storing, handling and using fuels - they are highly volatile and explosive in the vapor state. Do not add fuel while engine is running. Stop and cool the engine before adding fuel.

DO NOT SMOKE WHEN REFUELING!

SAFETY GUARDS

It is the owner's responsibility to ensure **ALL GUARDS AND SHIELDS** are in place and in working order.

IGNITION SYSTEMS

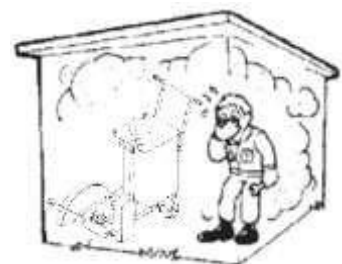

Breakerless magneto and batteries ignition systems **CAN CAUSE SEVERE**

ELECTRICAL SHOCKS, avoid contact with these components or their wiring.

SAFE DRESS

DO NOT WEAR loose clothing, rings, wristwatches, etc., near machinery.

NOISE PROTECTION

Wear O.S.H.A. specified hearing protection devices.

FOOT PROTECTION

Wear O.S.H.A. specified steel tip safety shoes.

HEAD PROTECTION

Wear O.S.H.A. specified safety helmets.

EYE PROTECTION

Wear O.S.H.A. specified eyes shields, safety glasses, and sweat bands.

DUST PROTECTION

Wear O.S.H.A. specified dust mask or respirator.

OPERATOR

Keep children and bystanders off and away from the equipment.



For details on safety rules and regulations in the United States, contact your local Occupational Safety and Health Administration (O.S.H.A.) office. Equipment operated in other countries must be operated and serviced in accordance and compliance with any and all safety requirements of such country. The publication of these safety precautions is done for your information does not by the publication of these precautions, imply or in any way represent that these are the sum of all dangers present near equipment. If you are operating this unit it is your responsibility to ensure that such operation is in full accordance with all applicable safety requirements and codes. All requirements of the United States Federal Occupational Safety and Health Administration Act must be met when operated in areas that are under the jurisdiction of that United States Department.

5. SAFETY NOTICE & DECALS



The "**SAFETY ALERT SYMBOL**" is used to call attention to items or operations that may be dangerous to those operating or working with this equipment. These symbols can be found throughout the manual and on the unit itself. Please read these warnings and cautions carefully.

READ SAFETY DECALS CAREFULLY

Carefully read and follow all safety decals. Keep them in good conditions. If they become aged, replace as required. If repainting, **REPLACE ALL** decals. Decals are available from your authorized Distributors. Decals are not shown to scale.

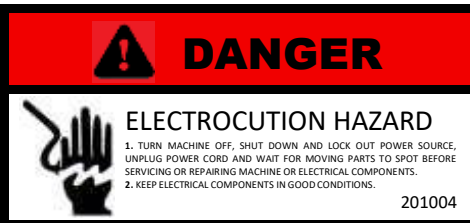

6. BEFORE OPERATING

- **REMEMBER!** It is the owner's responsibility to communicate information on the safe use and proper operation of this unit to the operators.
- Before operating, review SAFETY PRECAUTIONS on this manual.
- Familiarize yourself with the operation of the unit and confirm that all controls function properly BEFORE starting engine.
- Locate the killing switch and assure you know how to STOP the unit.
- Make sure hands, feet, and clothing are at a safe distance from any moveable parts prior to starting.
- Shrouds and grids are provided to protect the operator or structures in close proximity to rotating hot engine parts. It is the **RESPONSABILITY OF THE OPERATOR** to see that they are properly secured.

(956) 796 - 9411

- OIL LEVEL - Check the oil level in the engine. For more information see "Lubrication" under the engine "Owner's Manual" the "Maintenance" section of this manual.

All units come without oil on **ENGINE**. Running an engine without lubrication may damage this unit.

- AIR CLEANER - Check to ensure elements are in good condition and properly installed.
- Review every decal with the OPERATOR.
- FUEL SUPPLY – Engines require an automotive grade of clean, fresh, unleaded or regular gasoline. **All units come WITHOUT gasoline, oil or any other fluid.**
- FUEL FILTER - Check to ensure element is in good condition... Replace if it is clogged or damaged.
- LUBRICATION POINTS - Grease wheels (4), arbor shaft bearings (2) daily.
- POSITION – The only operating position for this saw is between the handle bars at the rear of the saw. If the operator must leave this position the engine must be shut down.
- SPECTATORS – Keep all personnel/spectators away from saw while cutting. Spinning diamonds blades can throw segments; abrasives blades can crack.

8. OPERATION INSTRUCTIONS

Prior to starting engine, make sure all guards are in place and secured and that the blade guard is at least 1" away from the cutting area.

REMEMBER! It is the owner's responsibility to communicate information on the safe use and proper operation of this unit to the operators.

IMPORTANT

Engine warranty is void if the engine is run without oil.

Check Gas engine

1. Open the fuel valve.
2. Pull the stop switch on the engine shroud to its "Out" position.
3. Move the engine throttle control to the "FAST" position.
4. Choke the engine X3 times for warming, if necessary.
5. Pull the starter string.
6. After the engine starts, move the choke lever to the open position, move the throttle level to the "IDLE" position and let the engine warm-up for one or two minutes.

Check Electric motor

1. Plug the motor into a suitable power source, according to the motor specs.
2. Move the switch on the motor to the "on" position.

OPERATING

1. Make sure the blade guard is at least 1" away from cutting area "IDLER" position.
2. Make sure the guards are securely locked before running engine.
3. Pull the stop switch on the engine shroud to its "Out" position.
4. Pull the engine starter string.



DO NOT OPERATE THIS UNIT WITH OUT BLADE GUARD!

5. SLOWLY LOWER BLADE INTO CUTTING. Lower saw blade until it just touches the pavement by turning the manual lift crank clockwise.
6. From this point, each ¼ turn of the lift/lower crank equals ¼" depth of cut.
7. **IT IS RECOMMENDED THAT SAW CUTS BE MADE BY 2" TO 3" INCREMENTS AT A TIME. GREATER DEPTHS OF CUT DAMAGE BLADE.**
8. Slowly push saw forward to desired cutting area.
9. Cut only in straight line using the saw pointer
10. To stop the engine, make sure to let the engine idle before stopping by using the crank lift handle to raise the saw height.
11. Push in the engine stop switch on the saw.
12. Close the fuel valve.
13. Discharge the water after to clean excess material.
14. Additional cleaning may be needed.

REMEMBER! It is the owner's responsibility to communicate information on the safe use and proper operation of this unit to the operators.

9. ADDING FLUIDS AND TOWING

GAS ENGINE

1. Move the engagement lever to the "IDLER" position and lock saw.
2. Pull off the engine stop switch on the saw console.
3. Close the fuel valve.
4. Add oil to continue operation / Drain oil if need oil change.
5. Add gasoline if needed.



STOP THE ENGINE OR ELECTRIC MOTOR BEFORE:

1. Adding fuel/Oil.
2. Leaving equipment unattended for any amount of time.
3. Making any repairs or adjustments to the unit.
4. Transportation.

IF LIFTING/LOWERING EQUIPMENT ALWAYS:

1. Leave lift/lower crank handle in locked position.
2. Stop the engine or electric motor.
3. REMOVE ALL BLADES (leave blade arbor, guards in place)
4. Lift the cutting guide to avoid any contact with the head.
5. Secure any other hardware on the saw.
6. Make sure you use appropriated lifting equipment rated to lift the saw. Have in mind the saw weight.
7. Do not position yourself where you could possibly be pinched / caught between saw and some other obstacle.



TRANSPORTING

1. Move saw on the jobsite by hand pushing. Do not tow the saw with another vehicle. The saw may be damage if towed.

CUTTING

1. Must know what you are sawing, before making any cuts. Be aware of all utilities i.e. gas/pipe lines, electricity, etc. take necessary precautions to prevent injury /death.

STORING

1. Drain fuel tank.
2. Remove blade, collar, and arbor nuts from both ends of arbor.
3. Clean arbor shaft, threats, blade collars and arbor nuts. Coat parts with grease.

4. Lube all bearings
5. Empty water system to avoid corrosion
6. Clean all moving parts with WD-40 lubricant.
7. Lower saw completely.
8. Cover saw for protection.



10. SERVICE INSTRUCTIONS

- Never service or lubricate the unit engine while running.
- After servicing the unit, restore and fasten all guards, shields, and covers to their original positions.
- Never drain oil into the ground, into open streams, or down sewage drains.

ENGINE

See engine owner's manual maintenance schedule.

If lost please visit <https://engines.honda.com/parts-and-support/owners-manuals> for more information.

ARBOR SET UP

1. Set each belt-arbor tension for 1/4" deflection with a 6 lbs. load in middle of belt span. Over tension or under tensioning belts will cause premature belt failure.
 - To adjust belt tension, loosen hex nut or belt tension bolt (two places).
 - To increase belt tension, turn tension bolts clockwise.
 - To decrease belt tension, turn tension bolts counter clockwise.

After adjusting belts, make sure engine mount is level to saw frame. Secure position of tension bolts by tightening hex nut (two places).

2. When replacing arbor shaft or pillow block bearings, always adjust bearings so arbor shaft runs PARALELL to rear axle. Torque bearings bolts to 60 ft. lbs.



**CLEAN AND INSPECT BLADE COLLARS EACH TIME BLADE IS INSTALLED.
REPLACE DAMAGED PARTS. TO REPLACE BLADE PIN, USE ARBOR PRESS
DO NOT USE A HAMMER.**

LUBRICATION

1. Grease wheels (4), arbor shaft bearings (2) daily. Use high quality gun grease.
2. Check water system for cleaning. 2 to 5 gallons per minute is required to for wet cutting. Use 3/4" ID hose to feed water to saw.

BLADE

1. Clean blade collars before installing new blade; inspect all blades before installing on saw. Ring test abrasive blades to make sure they are free from cracks; do not use abrasive blades that have been damaged i.e. missing blotters cracked or missing sections. Inspect diamonds blades to make sure they don't have missing segments or stress cracks.
2. Use only blades rates to operate arbor speed (3000 RPM). Use only proper size blade guards on your saw.

SAW BLADE INSTALLATION

1. Place saw on flat surface
2. Locate set screw/jam nut over right end of rear axle.
3. Loosen jam nut.
4. Turn set screw clockwise to remove saw rock on right front and left rear wheels.
5. Turn set screw counter clockwise to remove saw rock on left front and right rear wheels.
6. Hold set screw in desire position and tighten jam nut.

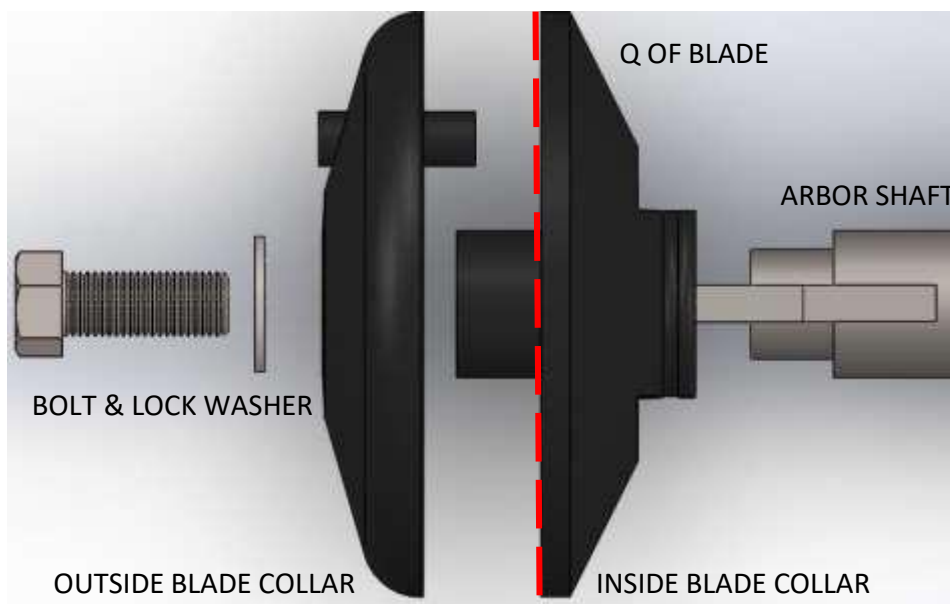

11. MAINTENANCE SCHEDULE

1. Check all hardware after the first 5 hours of use, then follow the maintenance schedule.
2. Check oil daily. Change after 5 (five) hours of use and every 25 hours after first change. Refer to engine manual for oil grades.
3. Grease wheels (4) and arbor shaft (2) daily. Use high quality gun grease, Kendall "SHP High temp" or equal.

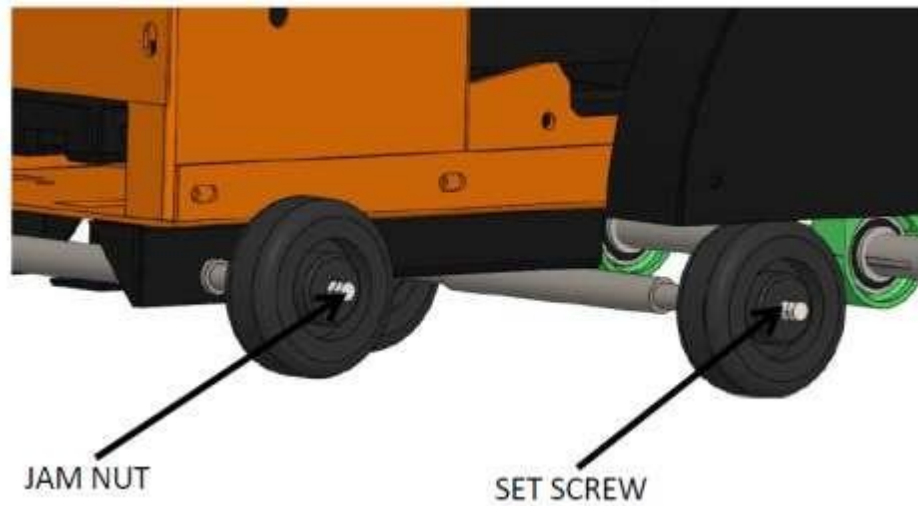

4. Clean air filter and foam pre-cleaner daily. More often if dry cutting. Always use foam element pre-cleaner over paper cartridge. Never run engine with clogged or missing air filter.
5. Re-check arbor belt tension after first 25 hours of operation. Set each belt for ¼" deflection with a 6lb load in middle of belt span. Over tensioning or under tensioning belts will cause premature belt fatigue. To adjust, loosen hex nut on belt tension bolt (2 places). To increase belt tension, turn tension bolts clockwise. To decrease belt tension, turn tension bolts counter clockwise. After adjusting belts make sure engine mount plate is LEVEL to frame. Secure position of tension bolts by tightening hex nuts.

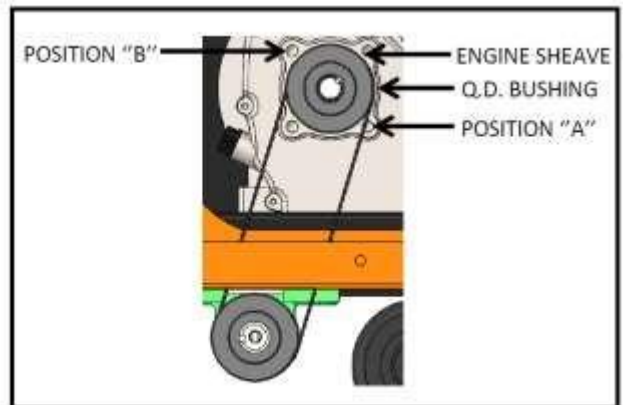
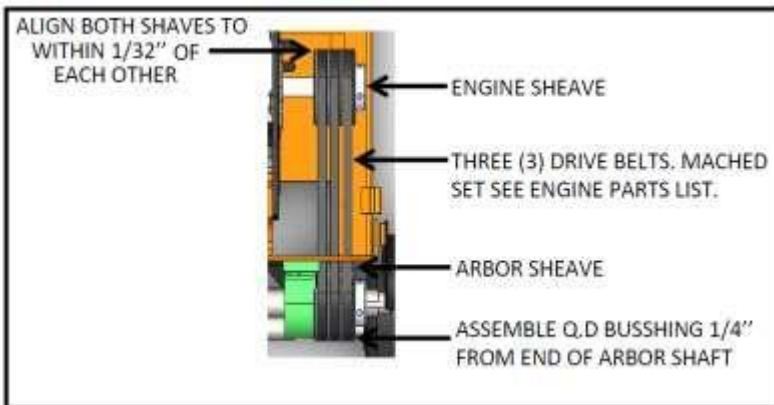

6. Re-torque the Blade and collar hardware after the first 25 hours of usage, and then follow the maintenance schedule.
7. Follow the maintenance schedule.

REMEMBER! ALWAYS USE PERSONAL SAFETY EQUIPMENT.

REMEMBER! It is the owner's responsibility to communicate information on the safe use and proper operation of this unit to the operators.

	<i>Maintenance</i>	<i>Each use</i>	<i>Every 20 hours</i>	<i>Every 50 hours</i>	<i>Every 100 hours</i>	<i>Yearly</i>
Engine	Refer to engine operator/owner manual	X				X
Air Cleaner	Refer to engine operator/owner manual	X				X
Oil	Oil change		X			
Bearings	Grease Arbor Shaft Bearings	X				X
V-Belts	Check for excessive wear		X			X
Arbor	Recheck arbor-belt tension		X			
Hardware	Check and tighten 1,2		X	X		X
Wheels	Grease wheels and check wear	X				X

12. REPLACEMENT

Parts

Tolerance or Replacement Cycle

Engine Components

- ✓ Refer to your engine manufacturer's Owner's Manual

V-Belts

- ✓ Replace if stretched to the point that the idler does not work properly. Replace the V-belts if they are cracked or torn.

Blades

- ✓ Replace if blade present any missing segments or stress cracks.

Arbor

- ✓ Replace arbor if: blade become loose or saws blades break constantly.

Hardware

- ✓ Re-torque all bolts after the first eight hours of operation and check hardware every 25 hours. Replace any worn or damaged hardware as needed. Replacement hardware should be grade 5 and zinc plated.

Safety Decals

- ✓ Replace if they become aged, damaged or cannot be easily read.

13. EQUIPMENT SPECS

MODEL	MSM	MCS-1	JCS	JCST
MAX Blade Capacity in (cm)	14" (35)	18" (45)	18" (45)	18" (45)
Operating Weight lbs. (Kg)	188 lbs. (85)	288 lbs. (130)	264 lbs. (120)	319 lbs. (145)
Front Wheel Size in (cm)	R-2" W-2" (5) (5)	R-2" W-2" (5) (5)	R-2.5" W-2" (6.3) (5)	R-2.5" W-2" (6.3) (5)
Rear Wheel Size in (cm)	R-3" W-2" (7.6) (5)	R-4" W-2" (10) (5)	R-3" W-2" (7.6) (5)	R-3" W-2" (7.6) (5)
Blade Collar Dia. in (cm)	3 1/2" (8.9)	4" (10.16)	3 1/2" (8.9)	3 1/2" (8.9)
Dimensions LxWxH in (cm)	36"x21"x36" (91)x(53)x(91)	42"x24"x37" (106)x(60)x(93)	42"x24"x39" (106)x(60)x(99)	45"x24"x39" (114)x(60)x(99)
Drive System	(3) cog V Belt	(3) cog V Belt	(3) cog V Belt	(4) cog V Belt
Water Tank Capacity Gal (Lt)	2.1gal (8) Optional	3.5 gal (13) Optional	10 gal (40)	N/A
Engine Power	GX160 -GX240 Honda	GX240 - GX390 Honda	GX240 - GX390 Honda	GX240 - GX390 Honda
Air Cleaner Type	Cyclone	Cyclone	Cyclone	Cyclone
Classification	Walk Behind	Walk Behind	Walk Behind	Self-Propelled
Blade Guard	1 Piece	Hinged	1 Piece	1 Piece

14. TORQUE CHART

APROXIMATE TIGHTENING TORQUE

SIZE	GRADE 2	GRADE 5	GRADE 8
# 10-24	21 in-lbs	32 in-lbs	45 in-lbs
# 10-32	23 in-lbs	36 in-lbs	51 in-lbs
1/4-20	49 in-lbs	76 in-lbs	9 in-lbs
1/4-28	56 in-lbs	87 in-lbs	10 in-lbs
5/16-18	8 in-lbs	13 in-lbs	18 in-lbs
5/16-24	9 in-lbs	14 in-lbs	20 in-lbs
3/8-16	15 in-lbs	23 in-lbs	33 in-lbs
3/8-24	17 in-lbs	26 in-lbs	37 in-lbs
7/16-14	24 in-lbs	37 in-lbs	52 in-lbs
7/16-20	27 in-lbs	41 in-lbs	58 in-lbs
1/2-13	37 in-lbs	57 in-lbs	80 in-lbs
1/2-20	41 in-lbs	64 in-lbs	90 in-lbs
9/16-12	53 in-lbs	82 in-lbs	115 in-lbs
9/16-18	59 in-lbs	82 in-lbs	129 in-lbs
5/8-11	73 in-lbs	112 in-lbs	159 in-lbs
5/8-18	83 in-lbs	112 in-lbs	180 in-lbs
3/4-10	129 in-lbs	223 in-lbs	282 in-lbs
3/4-16	144 in-lbs	200 in-lbs	315 in-lbs
7/8-9	125 in-lbs	322 in-lbs	454 in-lbs
7/8-14	138 in-lbs	355 in-lbs	501 in-lbs

APROXIMATE TIGHTENING TORQUE

SIZE	GRADE 2	GRADE 5	GRADE 8
1-8	188 ft-lbs	483 ft-lbs	682 ft-lbs
1-12	205 ft-lbs	529 ft-lbs	746 ft-lbs
1-14	210 ft-lbs	541 ft-lbs	764 ft-lbs
1-1/8-7	266 ft-lbs	596 ft-lbs	966 ft-lbs
1-1/8-12	297 ft-lbs	668 ft-lbs	1083 ft-lbs
1-1/4-7	375 ft-lbs	840 ft-lbs	1363 ft-lbs
1-1/4-12	415 ft-lbs	930 ft-lbs	1509 ft-lbs
1-3/8-6	491 ft-lbs	1102 ft-lbs	1787 ft-lbs
1-3/8-12	559 ft-lbs	1254ft-lbs	2034 ft-lbs
1-1/2-6	652 ft-lbs	1462ft-lbs	2371 ft-lbs
1-1/2-12	734 ft-lbs	1645ft-lbs	2668 ft-lbs
M 6	3 ft-lbs	4 ft-lbs	7 ft-lbs
M 8	6 ft-lbs	10 ft-lbs	18 ft-lbs
M 10	10 ft-lbs	20 ft-lbs	30 ft-lbs

CONVERSIONS

in - lbs x 0.083 = ft-lbs

ft - lbs x 12 = in-lbs

ft - lbs x 0.1383 = kg-m

ft - lbs x 1.3558 = N-m

15. WARRANTY

THIS IS YOUR WARRANTY – PLEASE READ AND SAVE

1. **TK Equip** warrants each new machine against any manufacturing defect in material and workmanship under normal use and service for a period of (1) one year. Warranty period begins on first day of use by end user. This first day of use is established by the date of a completed warranty card or a bill of sale to the end user.
2. **TK Equip** units offer a Life time warranty on Bearings & Seals. The obligation under this warranty is limited to the replacement of parts at your **TK Equip** factory branch or on an authorized **TK Equip** distributor.
3. Machines altered or modified without a **TK Equip** written consent may void this warranty policy immediately. Misuse, negligence, accidents or the operation of the machines in any other way that the recommended by **TK Equip** operation procedures, will void this warranty policy. This warranty shall not apply to machines repaired by other than authorized **TK Equip** branches or distributors.
4. The cost of transportation and other expenses related are not covered by this warranty.
5. Written authorization for the return of merchandise under warranty must be obtain from **TK Equip** customer service contact. All equipment & parts returned may be sent with a signed RGA (Return Goods Authorization) for its follow up.
6. **TK Equip** reserves the right to inspect and render the final decision on each warranty case.
7. **TK Equip** reserves the right to improve or make product changes without incurring any obligation to update, refit or install on machines previously sold.
8. **TK Equip** is not responsible for any liability, damage or injury directly or indirectly from the design, material or operation of its product.
9. The warranty letter must be returned to **TK Equip** within 10 days after purchase/acquire, for a first use failure warranty claim.
10. Warranty request must be submitted in written within 30 days after machine failure to **TK Equip** customer service.
11. THE FOREIGN WARRANTY IS EXPRESSLY IN LIEU OF ALL OTHER WARRANTIES, EXPRESSED OR IMPLIED, INCLUDING THE WARRANTIES OF MERCHANT ABILITY AND FITNESS FOR USE AND OF ALL OTHER OBLIGATION OR LIABILITIES ON OUR PART, AND WE NEITHER ASSUME NOR AUTHORIZE AINES, MOTOR AND THEIR COMPONENTS.NY OTHE RPERSON TO ASSUME FOR US ANY OF OUR PRODUCTS. LIKEWISE, THIS WARRANTY

(956) 796 - 9411

Control #: _____ (Dealer's internal #)

TK Equipment, Inc.

Lifetime Limited Warranty Application

This warranty application must be filled in by the dealer/distributor at the time of the sale. Please Print

TK Equipment Product Purchased at: _____ Phone (_____) _____

Street Address: _____

City: _____ State: _____ Zip: _____

Model No.: _____ Customer Invoice: _____ Date: __/__/__

16 DIGIT Serial No.: _____

Customer Name: _____ Phone: (_____) _____

Street Address: _____

City: _____ State: _____ Zip: _____

Representative Signature: _____ Date: __/__/__

Equipment's Owner Signature _____ Date: __/__/__

Additional Notes: _____

NOTE: To Register our unit, please send a copy by email to service@btmequipment.com or by fax to (956) 462-2500

Control #: _____



TK Equipment, Inc.

**Customer Life Time
Warranty Application**

***Dettach and keep on file**
(Check warranty policy for details)

Customer Signature

16. WAREHOUSE LOCATIONS

We are at your service

We have established a network of reputable distributors with trained mechanics and full facilities for maintenance and rebuilt, and to carry an adequate stock parts in all areas of the country. Their sales engineers are available for professional consultation. If you cannot locate your nearest distributor contact our sales branch listed below so we can point you in the right direction.

www.tkequip.com

salesmanager@tkequip.com

sales@tkequip.com

Office: 956-796-9411

Tel: 956-740-3740

Fax: 956-462-2500

