

Operator's Safety and Service

Masonry Block & Brick Saw

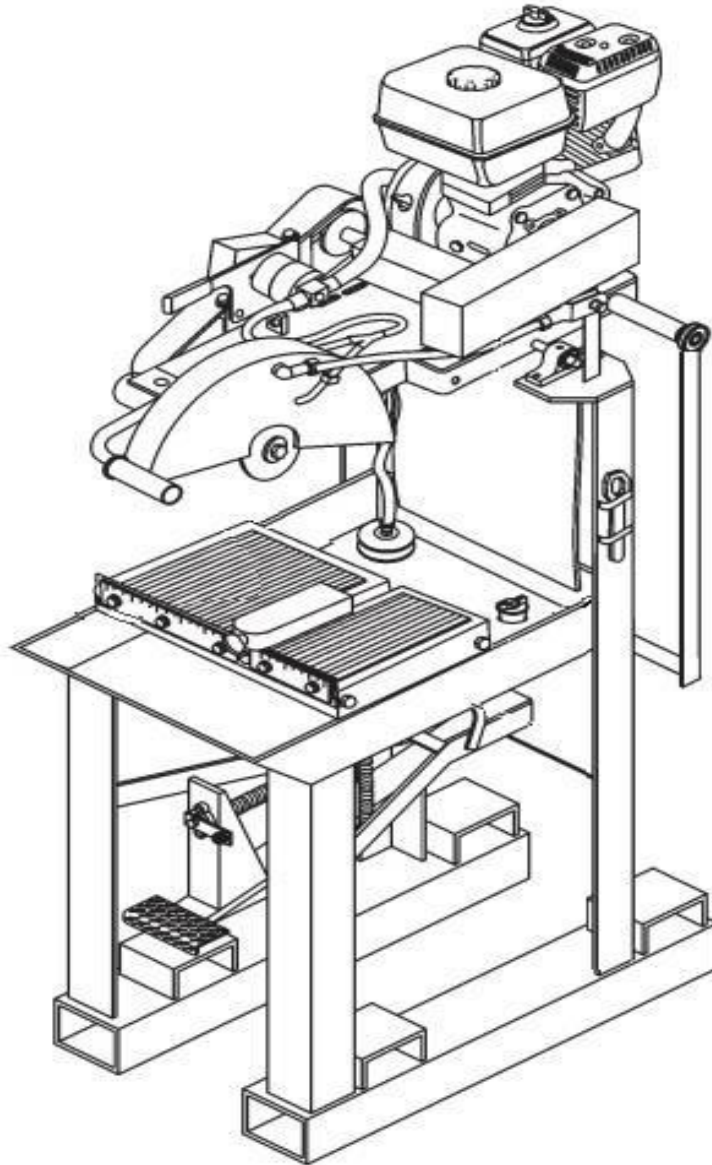

BBS20 / BBS20-E



01012019

It is the OWNER'S RESPONSABILITY to communicate information on the
SAFE USE and OPERATION of this machine to the operators.

TABLE OF CONTENTS

1.Serial Number Location.....	3
2.Parts Ordering Procedure	3
3.Operating Instructions	4
4.Safety Precaution	5
5.Safety Notice & Decals	8
6.Before Operating.....	10
7.Operation Instruction.....	10
8.Adding Fluids & Towing.....	12
9.Service Instructions	13
10. Water Pump	15
11.Maintenance Schedule	15
12.Replacements.....	18
13.Equipment General Specs	18
14.Warranty	19
15.Contact us	21
16.Additional Notes	22
17.Parts List Breakdown.....	Attachment

1. SERIAL NUMBER LOCATION

The model/serial number decal is located on the Frame.

(Write model number)

(Write serial number)

The unit year of manufacturing can be determined by its serial number. So, keep this information handy at all times, use your unit serial number when ordering parts.

This Unit warranty is stated in this Operational and Safety manual on page 16. Failure to return warranty registration card renders the warranty null and void.

An engine owner’s manual is also attached to every unit. Engine parts must be order from any authorized HONDA dealer, or other if different than HONDA. Refer to the engine owner’s manual lo learn about specifications and part identification.

2. PARTS ORDERING PROCEDURE:

Parts must be ordered through your local distributor or online using our partner internet parts dealers. If you can’t locate a local distributor in your area visit us online at www.tkequip.com for information so we can locate the nearest dealer and contact numbers for assistance.

Order Parts All Dealers are welcome to send us an email to: sevice@btmequipment.com or parts@btmequipment.com



All Dealers are welcome to order parts via fax by dialing **(956) 462-2500**



All Dealers are welcome to order parts by dialing our Number **(956) 796-9411**

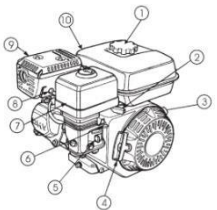

All HONDA warranties and parts ordering must be through your Honda dealers. Please visit <https://engines.honda.com/dealer-locator> for more information.

REMEMBER – You own the best. If repairs are needed use only OEM purchased parts from authorized distributors.

ALWAYS HAVE READY:

1. Dealer Account number
2. Dealer Name and Address
3. Shipping address and method of shipping if different than billing address.
4. Applicable model and serial number of machine(s).
5. Item part number(s), description, and quantity.

3. OPERATING INSTRUCTIONS

This Operation manual contains only standard parts. Variations of these parts as well as other special accessories are not included. Contact your local distributor for assistance in identifying parts not included in this manual.

ASSEMBLY INSTRUCTIONS

1. Remove the saw and all components from its shipping crate. You will see:
 - Preassembled Saw with no Blade, unless diamond blade was purchased separately before shipping.
 - Conveyor will be attached but on saw tray for better shipping.

Note: All installation hardware must be inserted into its respective location on the unit, reference parts breakdown for more details if needed.



Warning: failure to use proper lifting equipment could cause saw to fall and cause serious injury.

2. If saw is shipped regular, using appropriated equipment, bring the saw to the ground from its shipping pallet, all BBS saws have (4) forklift pockets for easy maneuver.



BLADE INSTALLATION/REMOVAL



IF BLADE GUARD IS TO BE REMOVED FOR BLADE SERVICE OR INSTALLATION, SAW MUST BE TURN OFF. NEVER RUN SAW WITHOUT BLADE GUARD INSTALLED.

1. Turn lift/lower crank to raise saw. Lock crank in place with locking handle.
2. Disconnect Spark plug wire.
3. Remove arbor bolt, lock washer, and outside blade collar with pin.
4. Clean and inspect arbor, lade, collars and bolts
5. Verify inside blade collar is fully engaged on arbor and key is positioned properly.
NOTE: BBS20 uses 1" diameters collar.
6. Mount blade over shoulder of outside collar. Pin must engage 3/8" diameter hole in blade. Many diamonds blades will have directional arrow on blade.
7. Re-Install outside blade collar and blade onto arbor shaft with 1" diameter shoulder and 3/8" pin engaging inside collar. Install bolt and torque at 60 ft. lbs.
8. Be sure that blade is installed to rotate in correct direction and that the saw is set up for required RPM.
9. Wet cutting diamonds blades must be used with water. Turn water on BEFORE STARTING CUTTING.

4. SAFETY PRECAUTIONS

 WARNING 

CALIFORNIA – Proposition 65 Warning

Engine exhaust and some of its constituents and some dust created by power sanding, sawing, grinding, drilling and other construction activities contains chemicals known to the State of California to cause cancer, birth defects and other reproductive harm.

Some examples of these chemicals are:

- Lead from lead-based paints
- Crystalline silica from bricks
- Cement and other masonry products
- Arsenic and chromium from chemically treated lumber

Your risk from these exposures varies, depending on how often you do this type of work. To reduce your exposure to these chemicals:

ALWAYS work in a well ventilated area, and work with approved safety equipment, such as dust masks that are specially designed to filter out microscopic particulates.

READ AND STUDY THE FOLLOWING SAFETY INFORMATION BEFORE ATTEMPTING TO OPERATE THIS EQUIPMENT. IN ADDITION, ENSURE THAT EVERY INDIVIDUAL WHO OPERATES OR WORKS WITH THIS EQUIPMENT IS FAMILIAR WITH THESE SAFETY PRECAUTIONS.

IT IS THE OPERATOR'S RESPONSIBILITY TO OPERATE OUR MACHINES ONLY WHEN WEARING THE PROPER PROTECTION RECOMMENDED BY THE OCCUPATIONAL SAFETY AND HEALTH ADMINISTRATION. HARM OR DEATH BY INHALING PARTICLES OR OTHER PHYSICAL INJURY MAY OCCUR IF THIS MACHINE IS OPERATED WITHOUT USING THE PROPER SAFETY GEAR, OR FOLLOWING THE APPROPRIATE PROCEDURES IN THIS MANUAL.

! WARNING !

www.P65warnings.ca.gov
Engine exhaust and some of its constituents, and some dust created by power sanding, sawing, grinding, drilling and other construction activities contains chemicals known to the State of California to cause cancer, birth defects and other reproductive harm.

Some examples of these chemicals are:

- Lead from lead-based paints.
- Crystalline silica from bricks.
- Cement and other masonry products.
- Arsenic and chromium from chemically treated lumber.

Your risk from these exposures varies, depending on how often you do this type of work. To reduce your exposure to these chemicals: ALWAYS work in a well ventilated area, and work with approved safety equipment, such as dust masks that are specially designed to filter out microscopic particles.

040620

! DANGER



- THE ENGINE EXHAUST AND SOME OF ITS CONSTITUENTS FROM THIS PRODUCT CAN EXPOSE YOU TO CHEMICALS INCLUDING CARBON.
- TO MINIMIZE EXPOSURE, AVOID BREATHING EXHAUST. ONLY USE THIS PRODUCT IN WELL VENTILATED AREAS. FOR MORE INFORMATION VISIT:
www.P65warning.ca.gov

DE1700

! WARNING

SILICOSIS WARNING

GRINDING/CUTTING/MIXING OF MASONRY, CONCRETE, METAL & OTHER MATERIALS WITH SILICA IN THEIR COMPOSITION MAY GIVE OFF DUST OR MISTS CONTAINING CRYSTALLINE SILICA. SILICA IS A BASIC COMPONENT OF SAND, QUARTZ, BRICK CLAY, GRANITE AND NUMEROUS OTHER MINERALS AND ROCKS. REPEATED AND/OR SUBSTANTIAL INHALATION OF AIRBORNE CRYSTALLINE SILICA CAN CAUSE SERIOUS OR FATAL RESPIRATORY DISEASES, INCLUDING SILICOSIS. IN ADDITION, CALIFORNIA AND SOME OTHER AUTHORITIES HAVE LISTED RESPIRABLE CRYSTALLINE SILICA AS A SUBSTANCE KNOWN TO CAUSE CANCER. WHEN CUTTING SUCH MATERIALS, ALWAYS FOLLOW THE RESPIRATORY PRECAUTIONS MENTIONED ABOVE.

! WARNING

SILICOSIS WARNING

GRINDING/CUTTING/MIXING OF MASONRY, CONCRETE, METAL & OTHER MATERIALS CAN GENERATE DUST, MISTS AND FUMES CONTAINING CHEMICALS KNOWN TO CAUSE SERIOUS OR FATAL INJURY OR ILLNESS, SUCH AS RESPIRATORY DISEASE, CANCER, BIRTH DEFECTS OR OTHER REPRODUCTIVE HARM. IF YOU ARE UNFAMILIAR WITH THE RISKS ASSOCIATED WITH THE PARTICULAR PROCESS AND/OR MATERIAL BEING CUT OR THE COMPOSITION OF THE TOOL BEING USED, REVIEW THE MATERIAL SAFETY DATA SHEET AND/OR CONSULT YOUR EMPLOYER, THE MATERIAL MANUFACTURER/SUPPLIER, GOVERNMENTAL AGENCIES SUCH AS OSHA AND NIOSH AND OTHER SOURCES ON HAZARDOUS MATERIALS. CALIFORNIA AND SOME OTHER AUTHORITIES, FOR INSTANCE, HAVE PUBLISHED LISTS OF SUBSTANCES KNOWN TO CAUSE CANCER, REPRODUCTIVE TOXICITY, OR OTHER HARMFUL EFFECTS. CONTROL DUST, MIST AND FUMES AT THE SOURCE WHERE POSSIBLE. IN THIS REGARD USE GOOD WORK PRACTICES AND FOLLOW THE RECOMMENDATIONS OF THE MANUFACTURERS OR SUPPLIERS, OSHA/NIOSH, AND OCCUPATIONAL AND TRADE ASSOCIATIONS. WATER SHOULD BE USED FOR DUST SUPPRESSION WHEN WET CUTTING IS FEASIBLE. WHEN THE HAZARDS FROM INHALATION OF DUST, MISTS AND FUMES CANNOT BE ELIMINATED, THE OPERATOR AND ANY BYSTANDERS SHOULD ALWAYS WEAR A RESPIRATOR APPROVED BY NIOSH/MSHA FOR THE MATERIALS BEING USED.

READ AND STUDY THE FOLLOWING SAFETY INFORMATION BEFORE ATTEMPTING TO OPERATE THIS EQUIPMENT. IN ADDITION, ENSURE THAT EVERY INDIVIDUAL WHO OPERATES OR WORKS WITH THIS EQUIPMENT IS FAMILIAR WITH THESE SAFETY PRECAUTIONS.

WARNING - LETHAL EXHAUST GAS!

An internal combustion engine discharges carbon monoxide, which is a poisonous and odorless invisible gas. Death or serious illness may result if inhaled. Operate only in an area with good ventilation. **NEVER IN A CONFINED AREA!**

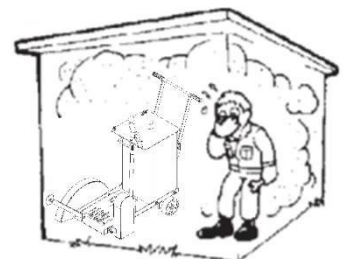

WARNING - DANGEROUS FUELS!

Use extreme caution when storing, handling and using fuels - they are highly volatile and explosive in the vapor state. Do not add fuel while engine is running. Stop and cool the engine before adding fuel.



DO NOT SMOKE WHEN REFUELING!

SAFETY GUARDS

It is the owner's responsibility to ensure **ALL GUARDS AND SHIELDS** are in place and in working order.

IGNITION SYSTEMS

Breakerless magneto and batteries ignition systems **CAN CAUSE SEVERE ELECTRICAL SHOCKS**, avoid contact with these components or their wiring.

SAFE DRESS

DO NOT WEAR loose clothing, rings, wristwatches, etc., near machinery.

NOISE PROTECTION

Wear O.S.H.A. specified hearing protection devices.

FOOT PROTECTION

Wear O.S.H.A. specified steel tip safety shoes.

HEAD PROTECTION

Wear O.S.H.A. specified safety helmets.

EYE PROTECTION

Wear O.S.H.A. specified eyes shields, safety glasses, and sweat bands.

DUST PROTECTION

Wear O.S.H.A. specified dust mask or respirator.

**OPERATOR**

Keep children and bystanders off and away from the equipment.

For details on safety rules and regulations in the United States, contact your local Occupational Safety and Health Administration (O.S.H.A.) office. Equipment operated in other countries must be operated and serviced in accordance and compliance with any and all safety requirements of such country. The publication of these safety precautions is done for your information does not by the publication of these precautions, imply or in any way represent that these are the sum of all dangers present near equipment. If you are operating this unit it is your responsibility to ensure that such operation is in full accordance with all applicable safety requirements and codes. All requirements of the United States Federal Occupational Safety and Health Administration Act must be met when operated in areas that are under the jurisdiction of that United States Department.

5. SAFETY NOTICE & DECALS**IMPORTANT NOTICE**

The "SAFETY ALERT SYMBOL" is used to call attention to items or operations that may be dangerous to those operating or working with this equipment. These symbols can be found throughout the manual and on the unit itself. Please read these warnings and cautions carefully.

READ SAFETY DECALS CAREFULLY

Carefully read and follow all safety decals. Keep them in good conditions. If they become aged, replace as required. If repainting, **REPLACE ALL** decals. Decals are available from your authorized Distributors. Decals are not shown to scale.

CAUTION

2-PERSON LIFT REQUIRED TO LIFT UNIT FROM GROUND ON/OFF VEHICLE

201155

EMERGENCY STOP PUSH TO STOP

WARNING

201005

DANGER

ELECTROCUTION HAZARD

- TURN MACHINE OFF, SHUT DOWN AND LOCK OUT POWER SOURCE, UNPLUG POWER CORD AND WAIT FOR MOVING PARTS TO STOP BEFORE SERVICING OR REPAIRING MACHINE OR ELECTRICAL COMPONENTS.
- KEEP ELECTRICAL COMPONENTS IN GOOD CONDITIONS.

201004

WARNING

MISSING GUARD HAZARD

INSTALL, CLOSE AND SECURE ALL GUARDS, SHIELDS AND HOODS BEFORE OPERATING.

201004

USE GASOLINE FUEL ONLY

201152

DANGER

FIRE HAZARD NO SMOKING

TO PREVENT SERIOUS INJURY OR DEATH FROM FIRE:

- DO NOT SMOKE WHEN REFUELING
- KEEP SPARKS, FLAMES, AND HOT MATERIAL AWAY FROM FLAMMABLE SUBSTANCES.

201005

WARNING

IMPROPER OPERATION OF THIS EQUIPMENT CAN CAUSE SERIOUS INJURY OR DEATH. READ OPERATOR'S MANUAL SUPPLIED WITH THIS MACHINE BEFORE OPERATION OR SERVICING. MODIFICATION OR ALTERATION OF THIS MACHINE WILL VOID MANUFACTURER'S WARRANTY. DO NOT ALTER OR MODIFY THIS MACHINE WITHOUT THE EXPRESS WRITTEN CONSENT OF THE MANUFACTURER.

201154

CAUTION

- THE ENGINE EXHAUST THE ENGINE EXHAUST AND SOME OF ITS CONSTITUENTS FROM THIS PRODUCT CAN EXPOSE YOU TO CHEMICALS INCLUDING CARBON MONOXIDE, AND HYDROCARBON THAT ARE KNOWN TO THE STATE OF CALIFORNIA TO CAUSE CANCER, BIRTH DEFECTS, AND OTHER REPRODUCTIVE HARM.
- TO MINIMIZE EXPOSURE, AVOID BREATHING EXHAUST. ONLY USE THIS PRODUCT IN WELL VENTILATED AREAS.

FOR MORE INFORMATION GO TO:
WWW.P65WARNING.CA.GOV

WARNING

SILICOSIS WARNING

GRINDING/CUTTING/MIXING OF MASONRY, CONCRETE, METAL AND OTHER MATERIALS CAN GENERATE DUST, MISTS AND FUMES CONTAINING CHEMICALS KNOWN TO CAUSE SERIOUS OR FATAL INJURY OR ILLNESS, SUCH AS RESPIRATORY DISEASE, CANCER, BIRTH DEFECTS OR OTHER REPRODUCTIVE HARM. IF YOU ARE UNFAMILIAR WITH THE RISKS ASSOCIATED WITH THE PARTICULAR PROCESS AND/OR MATERIAL BEING CUT OR THE COMPOSITION OF THE TOOL BEING USED, REVIEW THE MATERIAL SAFETY DATA SHEET AND/OR CONSULT YOUR EMPLOYER, THE MATERIAL MANUFACTURER/SUPPLIER, GOVERNMENTAL AGENCIES SUCH AS OSHA AND NIOSH AND OTHER SOURCES ON HAZARDOUS MATERIALS. CALIFORNIA AND SOME OTHER AUTHORITIES, FOR INSTANCE, HAVE PUBLISHED LISTS OF SUBSTANCES KNOWN TO CAUSE CANCER, REPRODUCTIVE TOXICITY, OR OTHER HARMFUL EFFECTS. CONTROL DUST, MIST AND FUMES AT THE SOURCE WHERE POSSIBLE. IN THIS REGARD USE GOOD WORK PRACTICES AND FOLLOW THE RECOMMENDATIONS OF THE MANUFACTURERS OR SUPPLIERS, OSHA/NIOSH, AND OCCUPATIONAL AND TRADE ASSOCIATIONS. WATER SHOULD BE USED FOR DUST SUPPRESSION WHEN WET CUTTING IS FEASIBLE. WHEN THE HAZARDS FROM INHALATION OF DUST, MISTS AND FUMES CANNOT BE ELIMINATED, THE OPERATOR AND ANY BYSTANDERS SHOULD ALWAYS WEAR A RESPIRATOR APPROVED BY NIOSH/MSHA FOR THE MATERIALS BEING USED.

CAUJOP220

WARNING

SILICOSIS WARNING

GRINDING/CUTTING/MIXING OF MASONRY, CONCRETE, METAL AND OTHER MATERIALS WITH SILICA IN THEIR COMPOSITION MAY GIVE OFF DUST OR MISTS CONTAINING CRYSTALLINE SILICA. SILICA IS A BASIC COMPONENT OF SAND, QUARTZ, BRICK CLAY, GRANITE AND NUMEROUS OTHER MINERALS AND ROCKS. REPEATED AND/OR SUBSTANTIAL INHALATION OF AIRBORNE CRYSTALLINE SILICA CAN CAUSE SERIOUS OR FATAL RESPIRATORY DISEASES, INCLUDING SILICOSIS. IN ADDITION, CALIFORNIA AND SOME OTHER AUTHORITIES HAVE LISTED RESPIRABLE CRYSTALLINE SILICA AS A SUBSTANCE KNOWN TO CAUSE CANCER. WHEN CUTTING SUCH MATERIALS, ALWAYS FOLLOW THE RESPIRATORY PRECAUTIONS MENTIONED ABOVE.

CAUJOP120

WARNING

ROTATING PART HAZARD KEEP AWAY

TO PREVENT SERIOUS INJURY OR DEATH ROTATING PARTS:

- INSTALL, CLOSE AND SECURE ALL GUARDS, SHIELDS AND HOODS BEFORE OPERATING.
- DO NOT PLACE HANDS IN DRUM UNLESS THE MOTOR OR ENGINE IS OFF AND THE POWER CORD UNPLUGGED OR THE KILL SWITCH ACTIVATED.
- KEEP HANDS, FEET, HAIR AND LOOSE CLOTHES AWAY FROM MOVING PARTS.

201003



6. BEFORE OPERATING

- **REMEMBER!** It is the owner's responsibility to communicate information on the safe use and proper operation of this unit to the operators.
- Before operating, review SAFETY PRECAUTIONS on this manual.
- Familiarize yourself with the operation of the unit and confirm that all controls function properly BEFORE starting engine.
- Locate the killing switch and assure you know how to STOP the unit. (if applies)
- Make sure hands, feet, and clothing are at a safe distance from any moveable parts prior to starting.
- Guards provide and protect the operator or structures in close proximity to rotating hot engine parts. It is the **RESPONSABILITY OF THE OPERATOR** to see that they are properly secured.
- OIL LEVEL - Check the oil level in the engine. For more information see "Lubrication" under the engine "Owner's Manual" the "Maintenance" section of this manual.

All units come without oil on **ENGINE**. Running an engine without lubrication may damage this unit.

- AIR CLEANER - Check to ensure elements are in good condition and properly installed.
- Review every decal with the OPERATOR.
- FUEL SUPPLY – Engines require an automotive grade of clean, fresh, unleaded or regular gasoline. **All units come WITHOUT gasoline, oil or any other fluid.**
- FUEL FILTER - Check to ensure element is in good condition... Replace if it is clogged or damaged.
- LUBRICATION POINTS - Grease wheels (4), arbor shaft bearings (2) daily.
- POSITION – The only operating position for this saw is between the handle bars at the rear of the saw. If the operator must leave this position the engine must be shut down.
- SPECTATORS – Keep all personnel/spectators away from saw while cutting. Spinning diamonds blades can throw segments; abrasives blades can crack.

7. OPERATION INSTRUCTIONS

Prior to starting engine, make sure all guards are in place and secured and that the blade guard is at least 1" away from the cutting area.

Check Gas engine

1. Open the fuel valve lever to ON position.
2. Place the Engine ON/OFF switch (Figure 19) in the "ON" position.
3. Move the engine throttle control to the "FAST" position. The engine governor speed is factory set to ensure optimum blade operating speeds

IMPORTANT
Engine warranty is void if the engine is run without oil.

4. Choke the engine X3 times for warming, if necessary.
5. Pull the starter string.
6. Before the saw is placed into operation, run the engine for several minutes. Check for fuel leaks, and noises that would associate with a loose guard and/or covers.
7. Gradually move the engine throttle lever toward the fast position. (All cutting should be done at full throttle) Squeeze the water pump priming bulb until water begins to flow through the water lines. If the pump is working correctly, the cutting blade should be covered with a steady water mist. This will keep the blade cool.

Check Electric motor

1. Plug the motor into a suitable power source, according to the motor specs.
2. Move the switch on the motor to the "on" position.

OPERATING

1. Make sure the blade guard is at least 1" away from cutting area "IDLE" position.
2. Make sure the guards are securely locked before running engine.
3. Pull the engine starter string.



DO NOT OPERATE THIS UNIT WITH OUT BLADE GUARD!

4. **FIX THE CUTTING HEIGHT.** Using the Raise/Lower Crank Handle, located above the step pedal, turn the handle **CLOCKWISE** to **LOWER** the saw blade to the required depth Turn the handle **COUNTERCLOCKWISE** to **RAISE** the saw blade to the required depth.
5. Place the material to be cut on the conveyor cart against the backstop. Push the conveyor cart, with the material in place, slowly and evenly until the cut is complete. When finished cutting, move the cart back and remove the cut pieces.
ALWAYS Cut only in straight line.

6. **PEDAL CUTTING.** Place the material to be cut on the conveyor cart against the backstop. With the blade away from the material to be cut, start the Motor (or Engine).

Move the conveyor cart, with the material in place, under the blade. Using your foot, depress the step pedal using a slow even pressure to lower the blade for cutting.

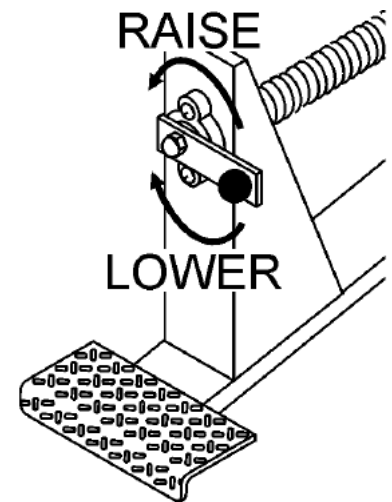

Raise/Lower Crank Handle

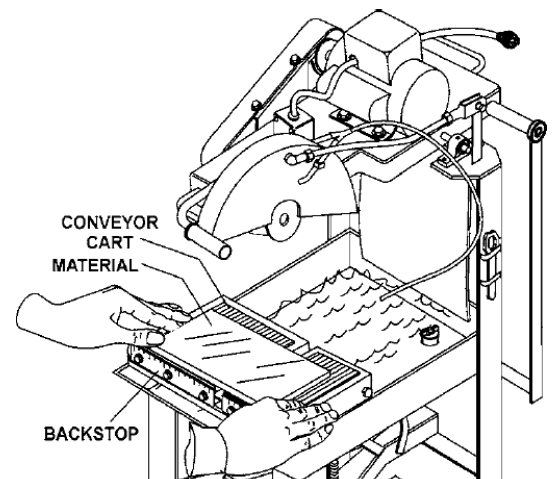

Material Placement

When finished cutting, slowly lift your foot up to raise the blade away from the conveyor cart and your cut material. Hold on to the mounting plate handle to prevent the plate from rising rapidly, possibly causing the saw to become unstable. DO NOT remove your foot from the step pedal until the blade has fully raised.

7. To stop the engine, make sure to let the engine idle before stopping by using the crank lift handle to raise the saw height.
8. Push in the engine stop switch on the saw on the engine/motor
9. Close the fuel valve.
10. Discharge the water after to clean excess material.
11. Additional cleaning may be needed.

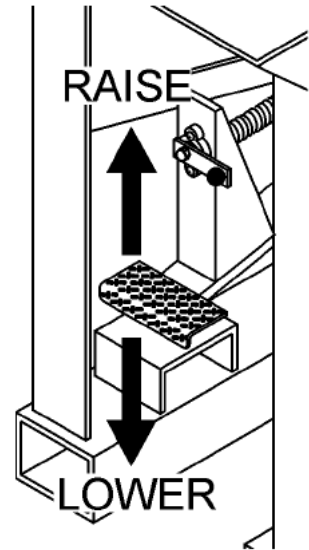

Raise/Lower Step Pedal

8. ADDING FLUIDS AND TOWING

GAS ENGINE

1. Move the engagement lever to the "IDLER" position and lock saw.
2. Pull off the engine stop switch.
3. Close the fuel valve.
4. Add oil to continue operation / Drain oil if need oil change.
5. Add gasoline if needed.



STOP THE ENGINE OR ELECTRIC MOTOR BEFORE:

1. Adding fuel/Oil.
2. Leaving equipment unattended for any amount of time.
3. Making any repairs or adjustments to the unit and/or transportation

IF LIFTING/LOWERING EQUIPMENT ALWAYS:

1. Leave lift/lower crank handle in locked position.
2. Stop the engine or electric motor.
3. REMOVE ALL BLADES (leave blade arbor, guards in place)
4. Lift the cutting guide to avoid any contact with the head.
5. Secure any other hardware on the saw.
6. Make sure you use appropriated lifting equipment rated to lift the saw. Have in mind the saw weight.
7. Do not position yourself where you could possibly be pinched / caught between saw and some other obstacle.

TRANSPORTING

1. Move saw on the jobsite with appropriate lifting equipment.

CUTTING

1. Must know what you are sawing, before making any cuts. Be aware of all utilities i.e. gas/pipe lines, electricity, etc. take necessary precautions to prevent injury /death.

STORING

1. Drain fuel tank.
2. Remove blade, collar, and arbor nuts from both ends of arbor.
3. Clean arbor shaft, threats, blade collars and arbor nuts. Coat parts with grease.
4. Lube all bearings
5. Empty water system to avoid corrosion
6. Clean all moving parts with WD-40 lubricant.
7. Lower saw completely.
8. Cover saw for protection.

9. SERVICE INSTRUCTIONS

- Never service or lubricate the unit engine while running.
- After servicing the unit, restore and fasten all guards, shields, and covers to their original positions.
- Never drain oil into the ground, into open streams, or down sewage drains.

ENGINE

See engine owner's manual maintenance schedule.

If lost please visit <https://engines.honda.com/parts-and-support/owners-manuals> for more information.

LUBRICATION

1. Grease wheels (4), arbor shaft bearings (2) daily. Use high quality gun grease.
2. Check water system for cleaning. 2 to 5 gallons per minute is required to for wet cutting. Use $\frac{3}{4}$ " ID hose to feed water to saw.

BLADE

1. Clean blade collars before installing new blade; inspect all blades before installing on saw. Ring test abrasive blades to make sure they are free from cracks; do not

use abrasive blades that have been damaged i.e. missing blotters cracked or missing sections. Inspect diamonds blades to make sure they don't have missing segments or stress cracks.

2. Use only blades rated to operate arbor speed of 3000 RPM. Use only proper size blade guards on your saw.



IF USING A SMALLER BLADE THAN 20" PLEASE CONTACT YOUR LOCAL DEALER FOR INSTRUCTION IN PULLEY CHANGES OR BLADE WILL RUN AT A HIGHER SPEED AND MAY CAUSE INJURY!

SAW BLADE INSTALLATION

1. Place saw on flat surface
2. Locate set screw/jam nut over right end of rear axle.
3. Loosen jam nut using the blade nut wrench that comes with the machine
4. Ensure the capacity of the blade guard matches the diameter of your cutting blade.
5. Turn set screw clockwise to remove saw rock on right front and left rear wheels.
6. Turn set screw counter clockwise to remove saw rock on left front and right rear wheels.
7. Using the blade nut wrench, remove the blade shaft nut and outside blade flange. Install the cutting blade onto the inside blade flange arbor. Re-install the outside blade flange and blade shaft nut. Tighten securely. **DO NOT overtighten.**

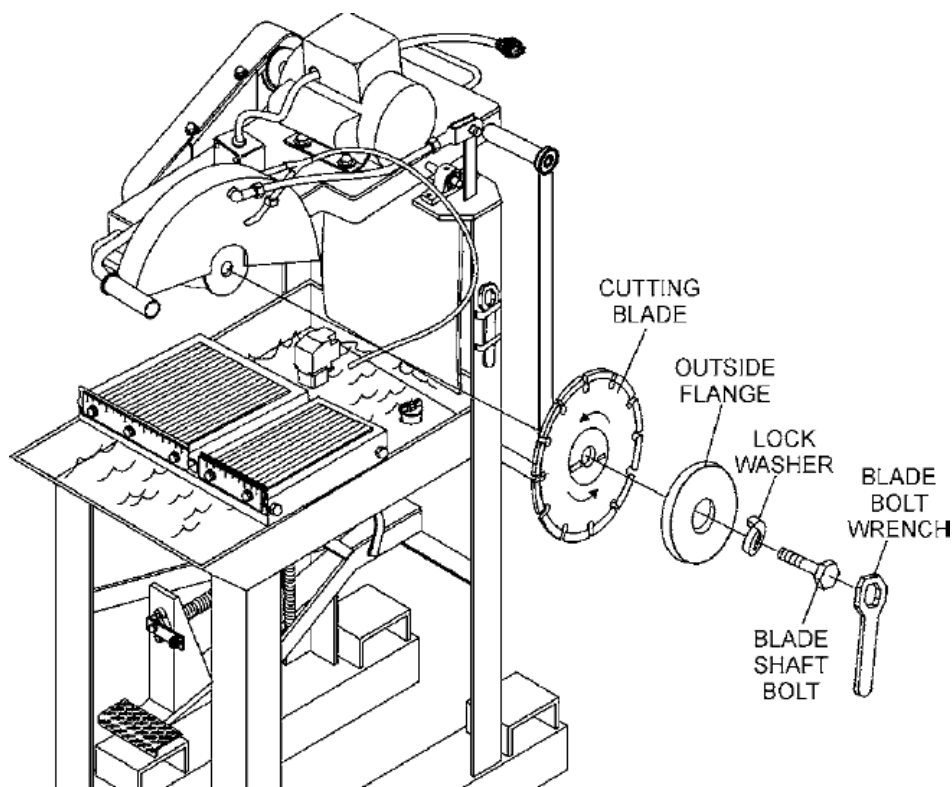

10. WATER PUMP (WET CUTTING)

WET CUTTING (GASOLINE ONLY)

To connect the mechanical water pump to the drive V-belts perform the following:

1. Loosen the 2 hex head cap screws (Figure 11) that secure the pump mount bracket.
2. Rotate the pump mounting bracket 'UP' to engage the pump drive wheel to the V-belts for water pump operations. The drive wheel should press down (belt deflection) approximately 1/8 to 3/16 inch to ensure proper connection.
3. Tighten the 2 hex head cap screws that secure the pump mount bracket.
4. With the engine running, squeeze the water pump priming bulb (Figure 12) until water begins to flow through the water lines. If the pump is working correctly, the cutting blade should be covered with a steady water mist. This will keep the blade cool while cutting.

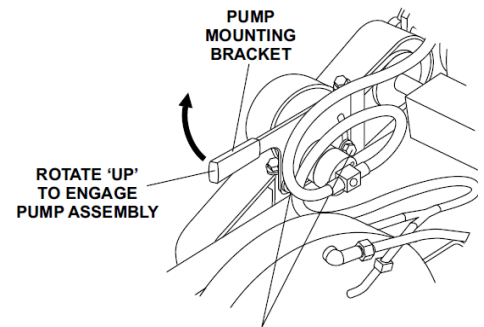

HEX HEAD CAP SCREWS
TO ADJUST POSITION OF
PUMP MOUNTING BRACKET

Pump Engage

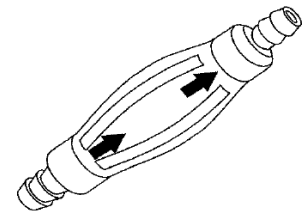

Priming Bulb

DRY CUTTING (GASOLINE ONLY)

If the nation of operations (the USA and Canada do not apply) permits DRY Sawing Operations, it is highly recommended to disengage the mechanical water pump as not to overheat the unit. To disconnect the mechanical water pump from the drive v-belts for DRY Cutting, perform the following:

1. Loosen the 2 hex head cap screws (Figure 13) that secure the pump mounting bracket.
2. Rotate the pump mounting bracket "DOWN" to disengage the drive wheel from the V-Belts.
3. Tighten the 2 hex head cap screws that secure the pump mount bracket.

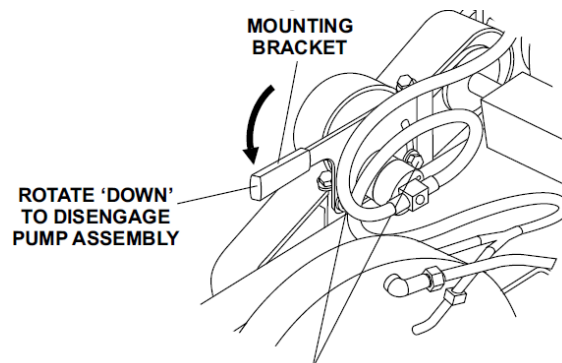

HEX HEAD CAP SCREWS
TO ADJUST POSITION OF
PUMP MOUNTING BRACKET

Pump Disengage

11. MAINTENANCE SCHEDULE

1. Check all hardware after the first 5 hours of use, then follow the maintenance schedule. Tighten loose nuts or screws and replace any cracked or broken parts.
2. Clean the machine frequently. DO NOT use aggressive cleaners (i.e. containing solvents). DO NOT use high-pressure water jets, aggressive detergents or solutions and liquids with a temperature exceeding 86°. Use a fluff-free cloth only. Use a cloth which may be lightly moistened only for removing dust and dirt. Hard packed dirt can be removed with a soft brush. DO NOT let any water/cleaning liquid/vapor penetrate into the electric motor, connectors/plugs, switches, etc. Cover all apertures, holes in the housing, connectors or plugs, etc., or seal them with adhesive tape. Use a soft, low-pressure water jet and a brush to rinse dirt and crustations away. Be particularly careful when near hazardous parts of the machine (e.g. switch, motor). Clean the motor and switches only by wiping with a moist cloth.
3. Check oil daily. Change after 5 (five) hours of use and every 25 hours after first change. Refer to engine manual for oil grades.
4. Grease arbor shaft (2) daily. Use high quality gun grease, Kendall "SHP High temp".
5. Lubricate the blade adjustment rod after every 8 hours of use.
6. Check the spindle bolt for tightness periodically.
7. **MAKE CERTAIN** that the cutting head is aligned properly. Misalignment can adversely affect blade life.
8. Clean air filter and foam pre-cleaner daily. More often if dry cutting. Always use foam element pre-cleaner over paper cartridge. Never run engine with clogged or no air filter.
9. Re-check arbor belt tension after first 25 hours of operation. Set each belt for ¼" deflection with a 6lb load in middle of belt span. Over tensioning or under tensioning belts will cause premature belt fatigue. To adjust, loosen hex nut on belt tension bolt (2 places). To increase belt tension, turn tension bolts clockwise. To decrease belt tension, turn tension bolts counter clockwise. After adjusting belts make sure engine mount plate is LEVEL to frame. Secure position of tension bolts by tightening hex nuts.
10. Re-torque the Blade and collar hardware after the first 25 hours of usage.
11. Grease pivot bearings periodically.

	<i>Maintenance</i>	<i>Each use</i>	<i>Every 20 hours</i>	<i>Every 50 hours</i>	<i>Every 100 hours</i>	<i>Yearly</i>
Engine	Refer to engine operator/owner manual	X				X
Air Cleaner	Refer to engine operator/owner manual	X				X
Oil	Oil change		X			
Bearings	Grease Arbor Shaft Bearings	X				X
V-Belts	Check for excessive wear		X			X
Arbor	Recheck arbor-belt tension		X			
Hardware	Check and tighten 1,2		X	X		X

BEARING LUBRICATION CARE

There are two (2) grease points for the BBS20-E (Electric Motors) and four (4) grease points for the BBS20-GH (Gasoline Engine). Use only Premium Lithium 12 based Grease, conforming to NLG1 Grade #1 consistency. Grease daily.

ADJUST BELT TENSION (GASOLINE POWERED SAWS)

1. Remove engine-to-jackshaft and jackshaft-to-blade shaft belt guards.
2. Check for proper belt tension on jackshaft-to-blade shaft belts and engine-to-jackshaft belts.
3. 4-5 lbs. of force applied to the mid-point between jackshaft and blade shaft pulleys should deflect the belt approximately 3/16" on a used belt.
4. 4-5 lbs. of force applied to the mid-point between engine and jackshaft pulleys should deflect the belt approximately 1/8".

To adjust engine-to-jackshaft belts only:

5. Loosen engine mounting bolts.
6. Adjust engine adjusting nuts to apply tension while maintaining pulley and belt alignment. Check pulley alignment and parallelism with a straight edge from jackshaft pulley to engine pulley.
7. When proper belt tension and parallelism have been achieved, tighten engine mounting bolts.

To adjust jackshaft-to-blade shaft belt:

If the jackshaft-to-blade shaft belt requires adjustment, also adjust the engine-to-jackshaft belts.

8. Loosen the 4 jackshaft mounting bolts, the 4 engine mounting bolts, and the jackshaft adjuster screw jam nuts (Loosen the mounting bolts to slide easily.)
9. Adjust jackshaft-to-blade shaft belt first. To increase tension, tighten adjuster on blade shaft belt side. To help maintain belt parallelism, loosen the jackshaft adjuster screw on the engine side the same number of turns that the blade shaft side adjuster screw was tightened. Using a straight edge on the blade shaft pulley to the jackshaft pulley, check for pulley alignment and belt parallelism.
10. When belt tension is correct, pulleys are aligned, and belts are parallel, tighten jackshaft mounting bolts and adjuster screw jam nuts.
11. Check for proper engine-to-jackshaft belt tension (4-5 lbs. with 1/8" deflection at mid-point between pulleys.)
12. Adjust engine adjuster bolts to apply proper tension while maintaining pulley alignment and belt parallelism. Check pulley alignment and parallelism with a straight edge from jackshaft pulley to engine pulley.
13. When proper belt tension and parallelism have been achieved, tighten engine mounting bolts.
14. Reinstall belt guards. Test saw operation.

Zerk Fittings Lubrication

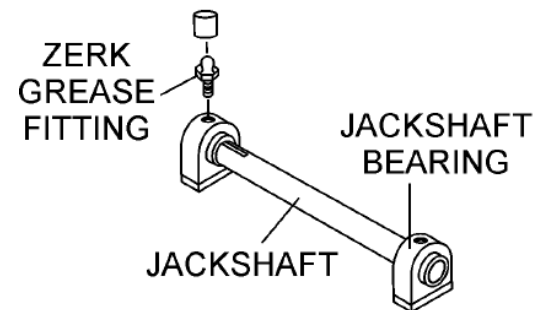
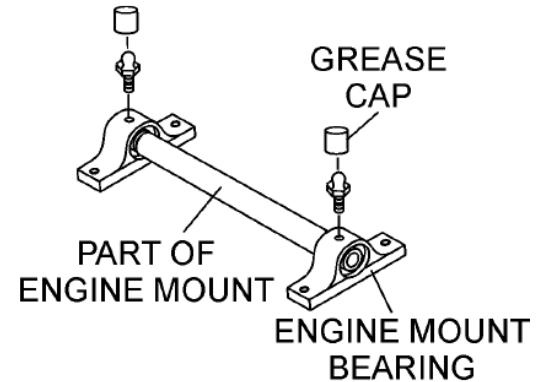

(GASOLINE MODELS ONLY)

12. REPLACEMENT

Parts

Tolerance or Replacement Cycle

Engine Components

V-Belts

- ✓ Refer to your engine manufacturer's Owner's Manual
- ✓ Replace if stretched to the point that the idler does not work properly. Replace the V-belts if they are cracked or torn.

Blades

- ✓ Replace if blade present any missing segments or stress cracks.

Arbor

- ✓ Replace arbor if: blade become loose or saws blades break constantly.

Hardware

- ✓ Re-torque all bolts after the first eight hours of operation and check hardware every 25 hours. Replace any worn or damaged hardware as needed. Replacement hardware should be grade 5 and zinc plated.

Safety Decals

- ✓ Replace if they become aged, damaged or cannot be easily read.

13. EQUIPMENT SPECS

MODEL	BBS20 E5	BBS20 GH13
MAX Blade Capacity in (cm)	20" (50)	20" (50)
Operating Weight lbs. (Kg)	580 lbs. (263)	580 lbs. (263)
Motor/Engine RPM	1725 RPM	3600 RPM
Depth of Cut	14" – 5 in 20" – 8 in	14" – 5 in 20" – 8 in
Dimensions LxWxH in (cm)	62"x25"x55" (157)x(63)x(140)	62"x25"x55" (157) x(63)x(140)
Water Pump source	Electric Powered	Engine Powered
Engine Power	5 HP (1PH/3PH) Baldor	GX390 Honda
Blade Guard	1 Piece	1 Piece

*For Electric Motors

- If 14" blade is used. Pulley size must be **5" diameter**
- If 20" blade is used. Pulley size must be **3-1/2" diameter**

*For Gas engines

14"-20" blade pulley size remains the same **4-1/4" diameter**.

14. WARRANTY

THIS IS YOUR WARRANTY – PLEASE READ AND SAVE

1. Before you use your machine please register your machine at <https://tkequip.com/warranty/>
2. **TK Equip** warrants each new machine against any manufacturing defect in material and workmanship under normal use and service for a period of (1) one year. Warranty period begins on first day of use by end user. This first day of use is established by the date of a completed warranty card registration online
3. We do not warranty engines. Engine warranty claims should be made directly to an authorized service center for the particular engine manufacturer. (Please see your engine manual for more details)
4. We reserve the choice to repair or replace. Parts such as engines, motors, pumps, valves, etc. furnished by our equipment but not manufactured by us. These parts will only carry the warranty of their original manufacturer except in special situations as decided upon by our representatives. Warranty claims should be reported immediately, continued use of the machine after a failure could result in additional damage and excessive wear not covered under the warranty terms
5. The obligation under this warranty is limited to the replacement of parts at your local dealer branch or on an authorized distributor. To access this warranty all equipment must be registered online once is purchased, otherwise we reserve the choice of authorization this warranty
6. Machines altered or modified without a written consent may void this warranty policy immediately. Misuse, negligence, accidents or the operation of the machines in any other way that the recommended by our operation procedures, will void this warranty policy. This warranty shall not apply to machines repaired by other than authorized dealer or distributors.
7. The cost of shipping and down time and other expenses related are not covered by this warranty.
8. Written authorization for the return of merchandise under warranty must be obtain from a member of our customer service. All equipment & parts returned may be sent with a signed RGA (Return Goods Authorization) for its follow up.
9. We reserve the right to inspect and render the final decision on each warranty case.
10. We reserve the right to improve or make product changes without incurring any obligation to update, refit or install on machines previously sold.
11. We are not responsible for any liability, damage or injury directly or indirectly from the design, material or operation of its product. It is the operator's responsibility to operate our machines only when wearing the proper protection recommended by the Occupational Safety and Health Administration. Harm or death by inhaling particles or other physical injury may occur if this machine is operated without using the proper safety gear, or following the appropriate procedures in this manual.
12. The detailed warranty letter or email must be returned to us within 10 days after purchase/acquired, for a first use failure warranty claim.
13. Warranty request must be submitted in written within 30 days after machine failure to any of our customer service representative.
14. THE FOREIGN WARRANTY IS EXPRESSLY IN LIEU OF ALL OTHER WARRANTIES, EXPRESSED OR IMPLIED, INCLUDING THE WARRANTIES OF MERCHANT ABILITY AND FITNESS FOR USE AND OF ALL OTHER OBLIGATION OR LIABILITIES ON OUR PART, AND WE NEITHER ASSUME NOR AUTHORIZE AINES, MOTOR AND THEIR COMPONENTS.NY OTHE RPERSON TO ASSUME FOR US ANY OF OUR PRODUCTS. LIKEWISE, THIS WARRANTY

(956) 796 - 9411

Control #: _____ (Dealer's internal #)

TK Equipment, Inc.

Lifetime Limited Warranty Application

This warranty application must be filled in by the dealer/distributor at the time of the sale. Please Print

TK Equipment Product Purchased at: _____ Phone (_____) _____

Street Address: _____

City: _____ State: _____ Zip: _____

Model No.: _____ Customer Invoice: _____ Date: __/__/__

16 DIGIT Serial No.: _____

Customer Name: _____ Phone: (_____) _____

Street Address: _____

City: _____ State: _____ Zip: _____

Representative Signature: _____ Date: __/__/__

Equipment's Owner Signature _____ Date: __/__/__

Additional Notes: _____

NOTE: To Register our unit, please send a copy by email to service@btmequipment.com or by fax to (956) 462-2500

Control #: _____



TK Equipment, Inc.

**Customer Life Time
Warranty Application**

***Dettach and keep on file**
(Check warranty policy for details)

Customer Signature

15. CONTACT US

We are at your service

We have established a network of reputable distributors with trained mechanics and full facilities for maintenance and rebuilt, and to carry an adequate stock parts in all areas of the country. Their sales engineers are available for professional consultation. If you cannot locate your nearest distributor contact our sales branch listed below so we can point you in the right direction.

www.tkequip.com

salesmanager@tkequip.com

sales@tkequip.com

Office: 956-796-9411

Tel: 956-740-3740

Fax: 956-462-2500

